



UNIVERSITY OF CAMBRIDGE INTERNATIONAL EXAMINATIONS  
International General Certificate of Secondary Education

CANDIDATE  
NAME

--	--	--	--	--

CENTRE  
NUMBER

--	--	--	--	--

CANDIDATE  
NUMBER

--	--	--	--



**MATHEMATICS**

**0580/41**

Paper 4 (Extended)

**October/November 2013**

**2 hours 30 minutes**

Candidates answer on the Question Paper.

Additional Materials:    Electronic calculator  
   Tracing paper (optional)

Geometrical instruments

---

**READ THESE INSTRUCTIONS FIRST**

Write your Centre number, candidate number and name on all the work you hand in.  
Write in dark blue or black pen.  
You may use a pencil for any diagrams or graphs.  
Do not use staples, paper clips, highlighters, glue or correction fluid.  
**DO NOT WRITE IN ANY BARCODES.**

Answer **all** questions.

If working is needed for any question it must be shown below that question.

Electronic calculators should be used.

If the degree of accuracy is not specified in the question, and if the answer is not exact, give the answer to three significant figures. Give answers in degrees to one decimal place.

For  $\pi$ , use either your calculator value or 3.142.

At the end of the examination, fasten all your work securely together.

The number of marks is given in brackets [ ] at the end of each question or part question.

The total of the marks for this paper is 130.

---

This document consists of **19** printed pages and **1** blank page.



1 David sells fruit at the market.

(a) In one week, David sells 120 kg of tomatoes and 80 kg of grapes.

(i) Write 80 kg as a fraction of the total mass of tomatoes and grapes.  
Give your answer in its lowest terms.

Answer(a)(i) ..... [1]

(ii) Write down the ratio mass of tomatoes : mass of grapes.  
Give your answer in its simplest form.

Answer(a)(ii) ..... : ..... [1]

(b) (i) One day he sells 28 kg of oranges at \$1.56 per kilogram.  
He also sells 35 kg of apples.  
The total he receives from selling the oranges and the apples is \$86.38 .

Calculate the price of 1 kilogram of apples.

Answer(b)(i) \$ ..... [2]

(ii) The price of 1 kilogram of oranges is \$1.56 .  
This is 20% more than the price two weeks ago.

Calculate the price two weeks ago.

Answer(b)(ii) \$ ..... [3]

(c) On another day, David received a total of \$667 from all the fruit he sold.  
The cost of the fruit was \$314.20 .  
David worked for  $10\frac{1}{2}$  hours on this day.

Calculate David's rate of profit in dollars per hour.

Answer(c) ..... dollars/h [2]

- 2 Emily cycles along a path for 2 minutes.  
 She starts from rest and accelerates at a constant rate until she reaches a speed of 5 m/s after 40 seconds.  
 She continues cycling at 5 m/s for 60 seconds.  
 She then decelerates at a constant rate until she stops after a further 20 seconds.

(a) On the grid, draw a speed-time graph to show Emily's journey.

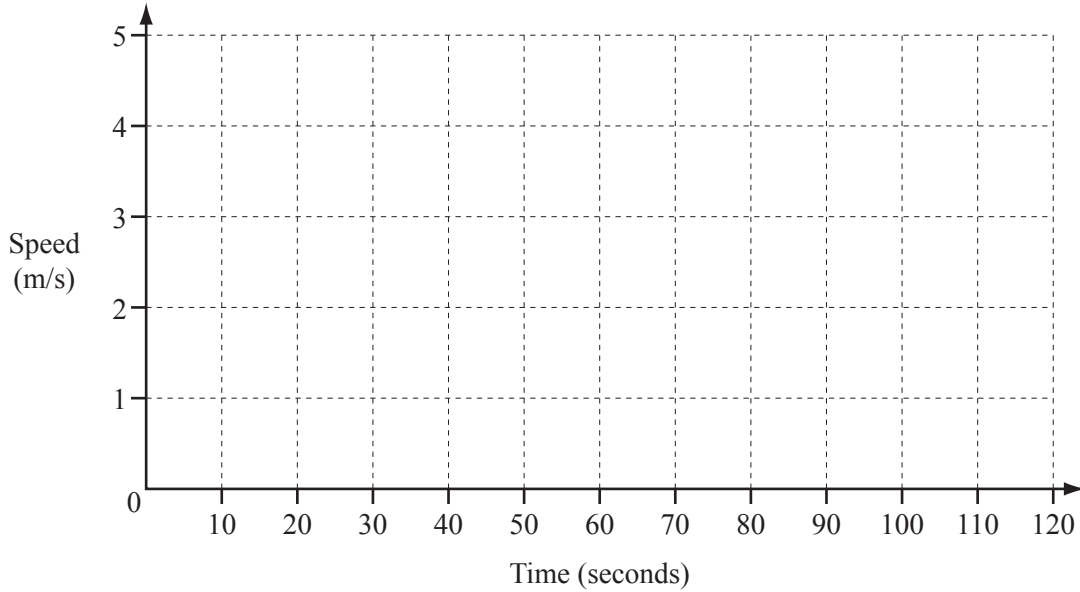

[2]

(b) Find Emily's acceleration.

Answer(b) ..... m/s<sup>2</sup> [1]

(c) Calculate Emily's average speed for the journey.

Answer(c) ..... m/s [4]

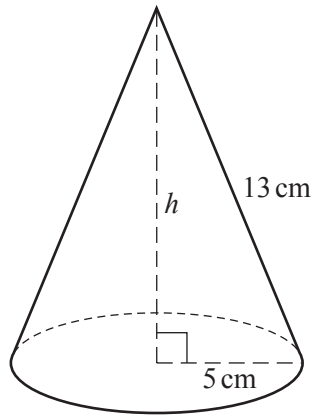
NOT TO  
SCALE

(a) The diagram shows a cone of radius 5 cm and slant height 13 cm.

(i) Calculate the curved surface area of the cone.

[The curved surface area,  $A$ , of a cone with radius  $r$  and slant height  $l$  is  $A = \pi r l$ .]

Answer(a)(i) ..... cm<sup>2</sup> [2]

(ii) Calculate the perpendicular height,  $h$ , of the cone.

Answer(a)(ii)  $h =$  ..... cm [3]

(iii) Calculate the volume of the cone.

[The volume,  $V$ , of a cone with radius  $r$  and height  $h$  is  $V = \frac{1}{3}\pi r^2 h$ .]

Answer(a)(iii) ..... cm<sup>3</sup> [2]

(iv) Write your answer to **part (a)(iii)** in cubic metres.

Give your answer in standard form.

Answer(a)(iv) ..... m<sup>3</sup> [2]

(b)

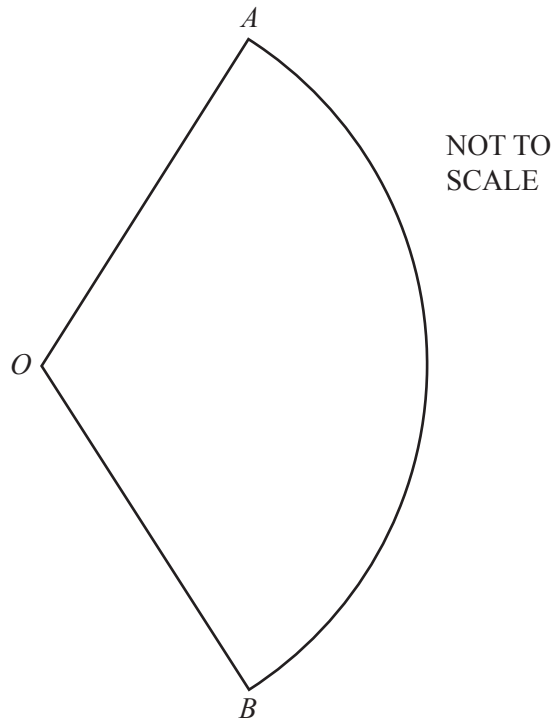
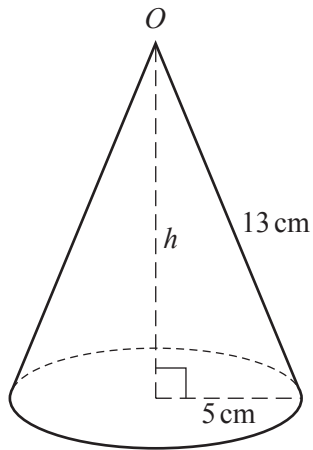

The cone is now cut along a slant height and it opens out to make the sector  $AOB$  of a circle.

Calculate angle  $AOB$ .

*Answer(b)* Angle  $AOB$  = ..... [4]

4

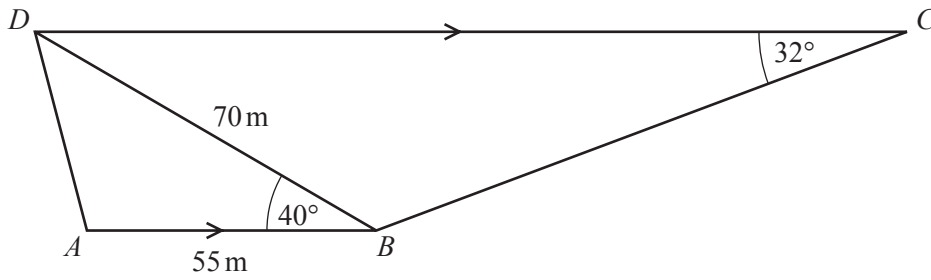
NOT TO  
SCALEFor  
Examiner's  
Use

The diagram shows a school playground  $ABCD$ .

$ABCD$  is a trapezium.

$AB = 55$  m,  $BD = 70$  m, angle  $ABD = 40^\circ$  and angle  $BCD = 32^\circ$ .

(a) Calculate  $AD$ .

Answer(a)  $AD = \dots\dots\dots$  m [4]

(b) Calculate  $BC$ .

Answer(b)  $BC = \dots\dots\dots$  m [4]

- (c) (i) Calculate the area of the playground  $ABCD$ .

*Answer(c)(i)* ..... m<sup>2</sup> [3]

- (ii) An accurate plan of the school playground is to be drawn to a scale of 1:200 .

Calculate the area of the school playground on the plan.  
Give your answer in cm<sup>2</sup>.

*Answer(c)(ii)* ..... cm<sup>2</sup> [2]

- (d) A fence,  $BD$ , divides the playground into two areas.

Calculate the shortest distance from  $A$  to  $BD$ .

*Answer(d)* ..... m [2]

---

5 (a)

For  
Examiner's  
Use

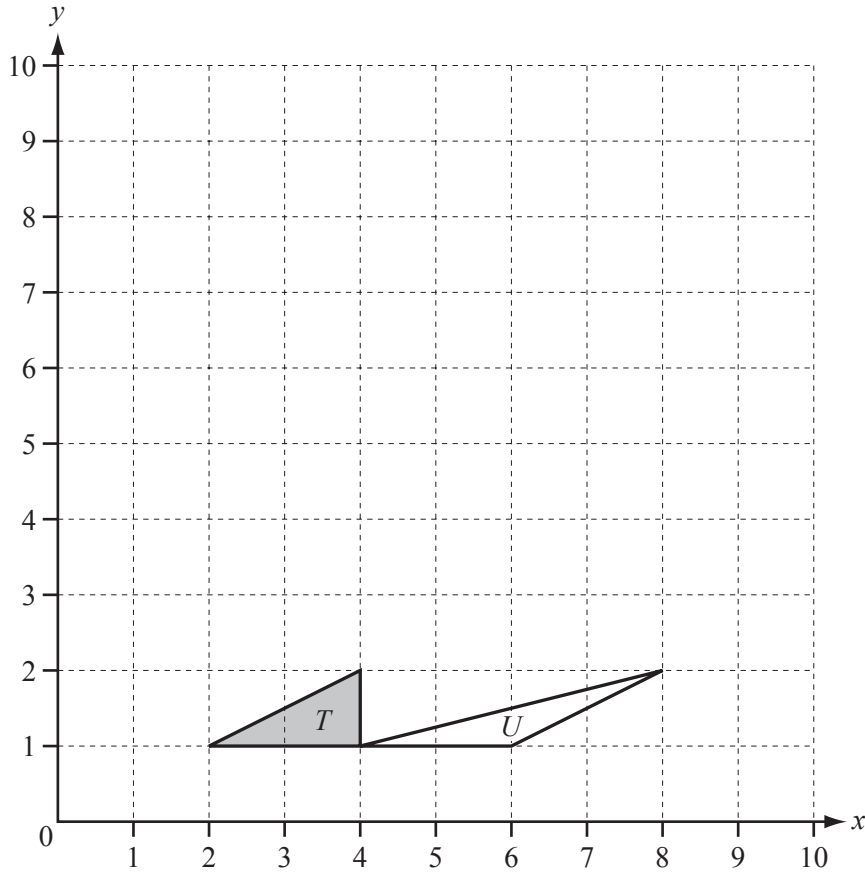

- (i) Draw the reflection of triangle  $T$  in the line  $y = 5$ . [2]
- (ii) Draw the rotation of triangle  $T$  about the point  $(4, 2)$  through  $180^\circ$ . [2]
- (iii) Describe fully the **single** transformation that maps triangle  $T$  onto triangle  $U$ .  
*Answer(a)(iii)* ..... [3]
- (iv) Find the  $2 \times 2$  matrix which represents the transformation in **part (a)(iii)**.

*Answer(a)(iv)*  $\left( \begin{array}{cc} & \\ & \end{array} \right)$  [2]



(b)

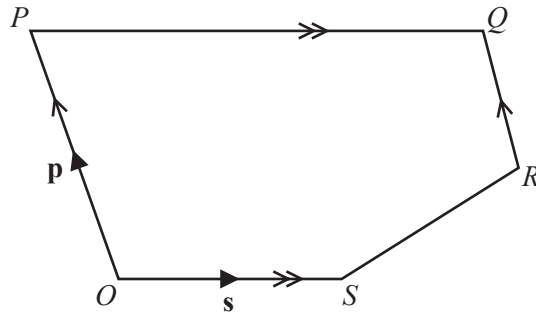

NOT TO  
SCALE

In the pentagon  $OPQRS$ ,  $OP$  is parallel to  $RQ$  and  $OS$  is parallel to  $PQ$ .  
 $PQ = 2OS$  and  $OP = 2RQ$ .  
 $O$  is the origin,  $\vec{OP} = \mathbf{p}$  and  $\vec{OS} = \mathbf{s}$ .

Find, in terms of  $\mathbf{p}$  and  $\mathbf{s}$ , in their simplest form,

- (i) the position vector of  $Q$ ,

Answer(b)(i) ..... [2]

- (ii)  $\vec{SR}$ .

Answer(b)(ii)  $\vec{SR} =$  ..... [2]

- (c) Explain what your answers in **part (b)** tell you about the lines  $OQ$  and  $SR$ .

Answer(c) ..... [1]

6 (a)

For  
Examiner's  
Use

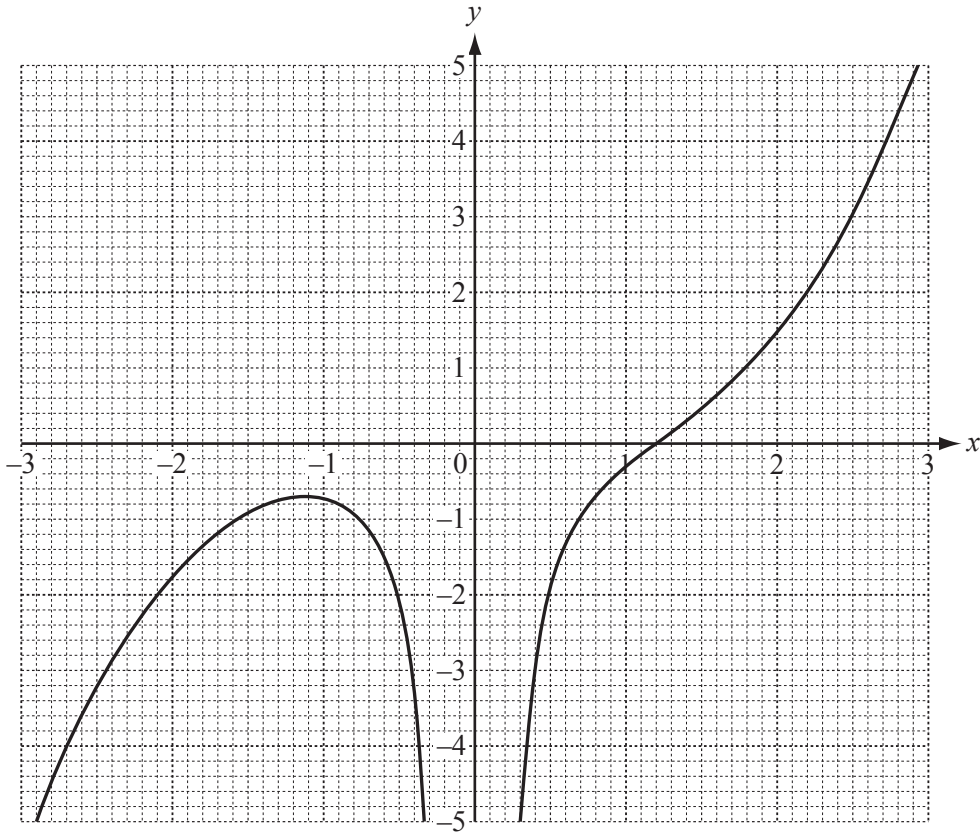

The diagram shows the graph of  $y = f(x)$  for  $-3 \leq x \leq 3$ .

(i) Find  $f(2)$ .

Answer(a)(i) ..... [1]

(ii) Solve the equation  $f(x) = 0$ .

Answer(a)(ii)  $x =$  ..... [1]

(iii) Write down the value of the largest integer,  $k$ , for which the equation  $f(x) = k$  has 3 solutions.

Answer(a)(iii)  $k =$  ..... [1]

(iv) By drawing a suitable straight line, solve the equation  $f(x) = x$ .

Answer(a)(iv)  $x =$  ..... or  $x =$  ..... or  $x =$  ..... [3]

(b)  $g(x) = 1 - 2x$        $h(x) = x^2 - 1$

(i) Find  $gh(3)$ .

*Answer(b)(i)* ..... [2]

(ii) Find  $g^{-1}(x)$ .

*Answer(b)(ii)*  $g^{-1}(x) =$  ..... [2]

(iii) Solve the equation  $h(x) = 3$ .

*Answer(b)(iii)*  $x =$  ..... or  $x =$  ..... [3]

(iv) Solve the equation  $g(3x) = 2x$ .

*Answer(b)(iv)*  $x =$  ..... [3]

---

*For  
Examiner's  
Use*

- 7 120 students are asked to answer a question.  
The time,  $t$  seconds, taken by each student to answer the question is measured.  
The frequency table shows the results.

Time	$0 < t \leq 10$	$10 < t \leq 20$	$20 < t \leq 30$	$30 < t \leq 40$	$40 < t \leq 50$	$50 < t \leq 60$
Frequency	6	44	40	14	10	6

- (a) Calculate an estimate of the mean time.

Answer(a) ..... s [4]

- (b) (i) Complete the cumulative frequency table.

Time	$t \leq 10$	$t \leq 20$	$t \leq 30$	$t \leq 40$	$t \leq 50$	$t \leq 60$
Cumulative frequency	6			104		120

[2]

- (ii) On the grid below, draw a cumulative frequency diagram to show this information.

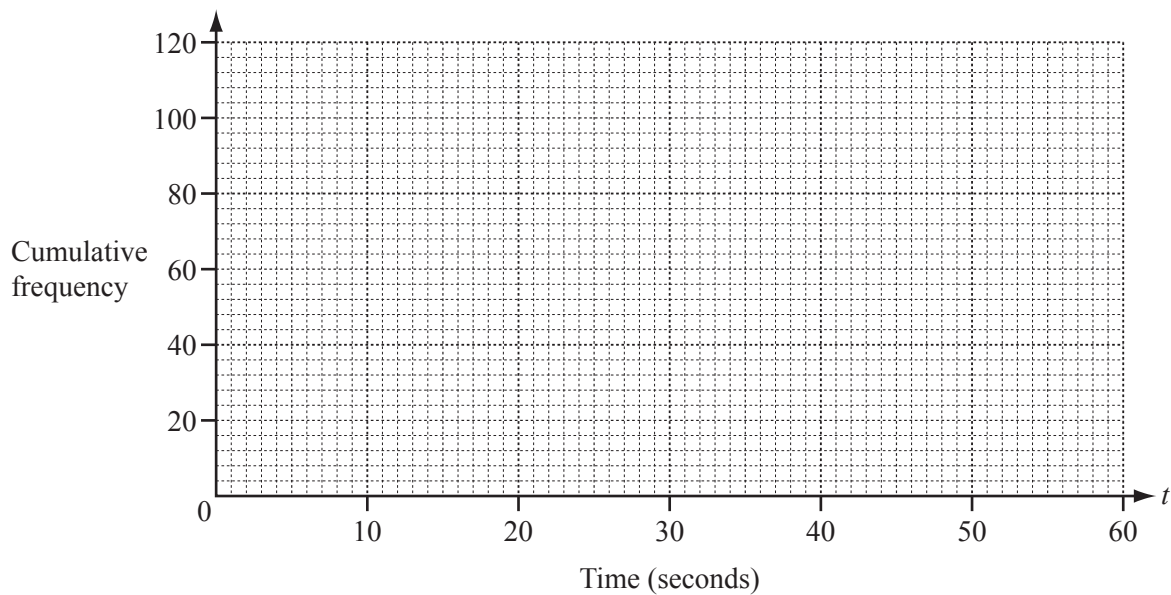

[3]

- (iii) Use your cumulative frequency diagram to find the median, the lower quartile and the 60th percentile.

Answer(b)(iii) Median ..... s  
 Lower quartile ..... s  
 60th percentile ..... s [4]

- (c) The intervals for the times taken are changed.

- (i) Use the information in the **frequency table** on the opposite page to complete this new table.

Time	$0 < t \leq 20$	$20 < t \leq 30$	$30 < t \leq 60$
Frequency		40	

[2]

- (ii) On the grid below, complete the histogram to show the information in the new table. One column has already been drawn for you.

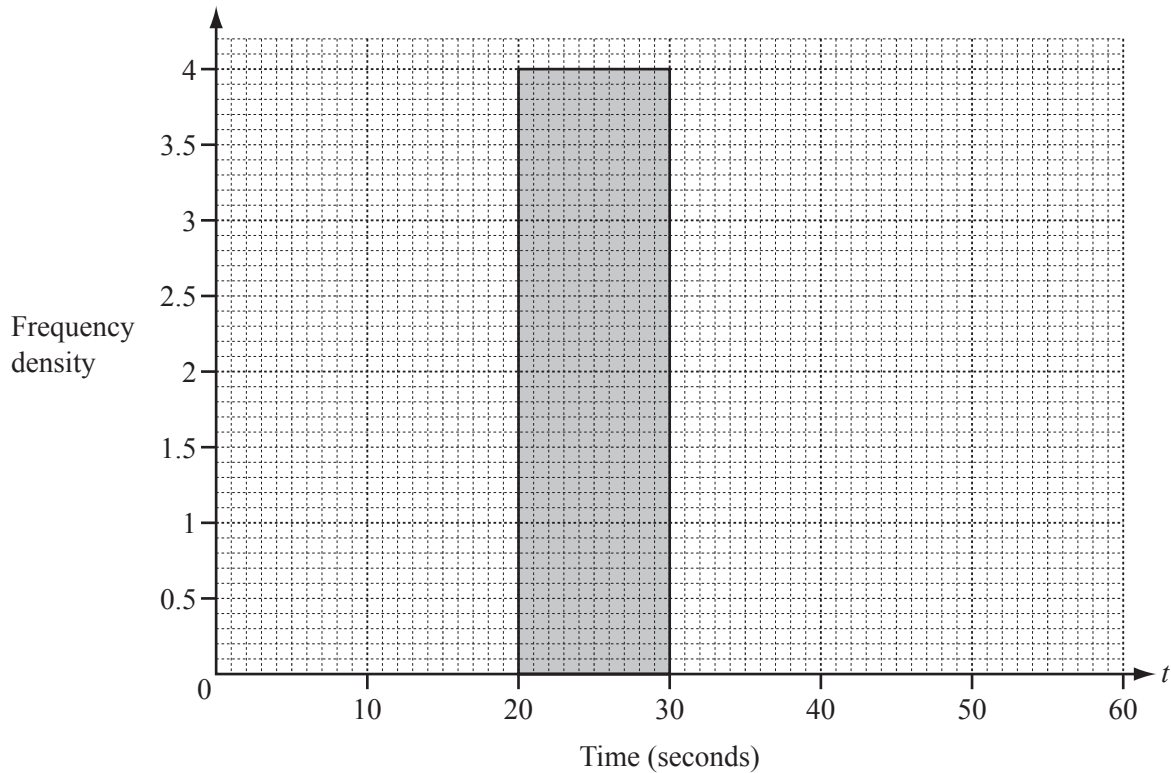

[3]

- 8 (a) Solve the equation  $8x^2 - 11x - 11 = 0$ .  
Show all your working and give your answers correct to 2 decimal places.

*Answer(a)*  $x = \dots\dots\dots$  or  $x = \dots\dots\dots$  [4]

- (b)  $y$  varies directly as the square root of  $x$ .  
 $y = 18$  when  $x = 9$ .

Find  $y$  when  $x = 484$ .

*Answer(b)*  $y = \dots\dots\dots$  [3]

- (c) Sara spends  $\$x$  on pens which cost  $\$2.50$  each.  
She also spends  $\$(x - 14.50)$  on pencils which cost  $\$0.50$  each.  
The **total** of the number of pens and the number of pencils is 19.

Write down and solve an equation in  $x$ .

*For  
Examiner's  
Use*

*Answer(c)*  $x = \dots\dots\dots$  [6]

---

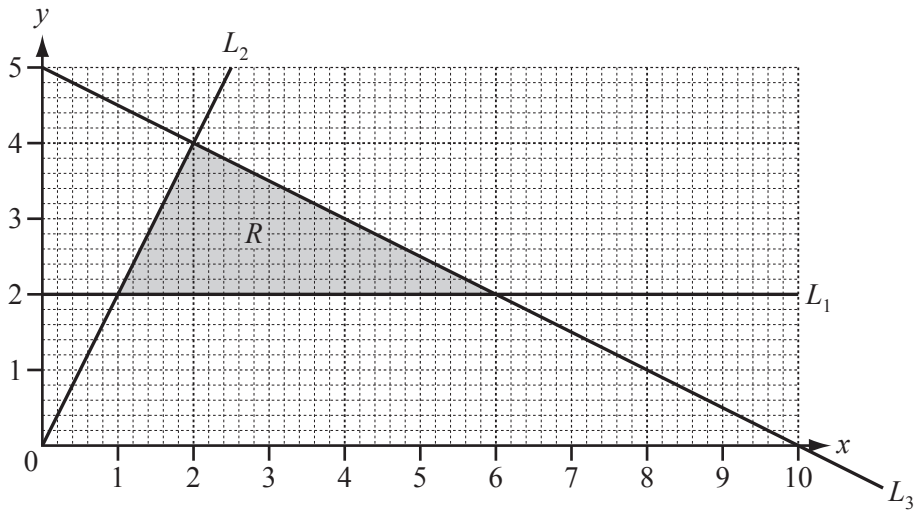

(a) Find the equations of the lines  $L_1$ ,  $L_2$  and  $L_3$ .

Answer(a)  $L_1$  .....

$L_2$  .....

$L_3$  ..... [5]

(b) Write down the three inequalities that define the shaded region,  $R$ .

Answer(b) .....

.....

..... [3]



- (c) A gardener buys  $x$  bushes and  $y$  trees.  
The cost of a bush is \$30 and the cost of a tree is \$200.  
The shaded region  $R$  shows the only possible numbers of bushes and trees the gardener can buy.

- (i) Find the number of bushes and the number of trees when the total cost is \$720.

*Answer(c)(i)* ..... bushes  
..... trees [2]

- (ii) Find the number of bushes and the number of trees which give the greatest possible total cost.  
Write down this greatest possible total cost.

*Answer(c)(ii)* ..... bushes  
..... trees  
Greatest possible total cost = \$ ..... [3]

---

<b>10 (a)</b>	1	=	1
	1 + 2	=	3
	1 + 2 + 3	=	6
	1 + 2 + 3 + 4	=	10

(i) Write down the next line of this pattern.

*Answer(a)(i)* ..... [1]

(ii) The sum of the first  $n$  integers is  $\frac{n}{k}(n + 1)$ .

Show that  $k = 2$ .

*Answer(a)(ii)*

[2]

(iii) Find the sum of the first 60 integers.

*Answer(a)(iii)* ..... [1]

(iv) Find  $n$  when the sum of the first  $n$  integers is 465.

*Answer(a)(iv)*  $n =$  ..... [2]

(v)  $1 + 2 + 3 + 4 + \dots + x = \frac{(n - 8)(n - 7)}{2}$

Write  $x$  in terms of  $n$ .

*Answer(a)(v)*  $x =$  ..... [1]

<b>(b)</b>	$1^3$	$= 1$
	$1^3 + 2^3$	$= 9$
	$1^3 + 2^3 + 3^3$	$= 36$
	$1^3 + 2^3 + 3^3 + 4^3$	$= 100$

**(i)** Complete the statement.

$$1^3 + 2^3 + 3^3 + 4^3 + 5^3 = \dots\dots\dots = (\dots\dots\dots)^2 \quad [2]$$

**(ii)** The sum of the first  $n$  integers is  $\frac{n}{2}(n + 1)$ .

Find an expression, in terms of  $n$ , for the sum of the first  $n$  cubes.

*Answer(b)(ii)* ..... [1]

**(iii)** Find the sum of the first 19 cubes.

*Answer(b)(iii)* ..... [2]

**BLANK PAGE**

---

Permission to reproduce items where third-party owned material protected by copyright is included has been sought and cleared where possible. Every reasonable effort has been made by the publisher (UCLES) to trace copyright holders, but if any items requiring clearance have unwittingly been included the publisher will be pleased to make amends at the earliest possible opportunity.

University of Cambridge International Examinations is part of the Cambridge Assessment Group. Cambridge Assessment is the brand name of University of Cambridge Local Examinations Syndicate (UCLES), which is itself a department of the University of Cambridge.